

PX50 Apartment Compactor

2/1/2024

v. 1

Side Access, Rear Door Thru Wall, Integral Power Unit

Site Spacing and Slab Requirements

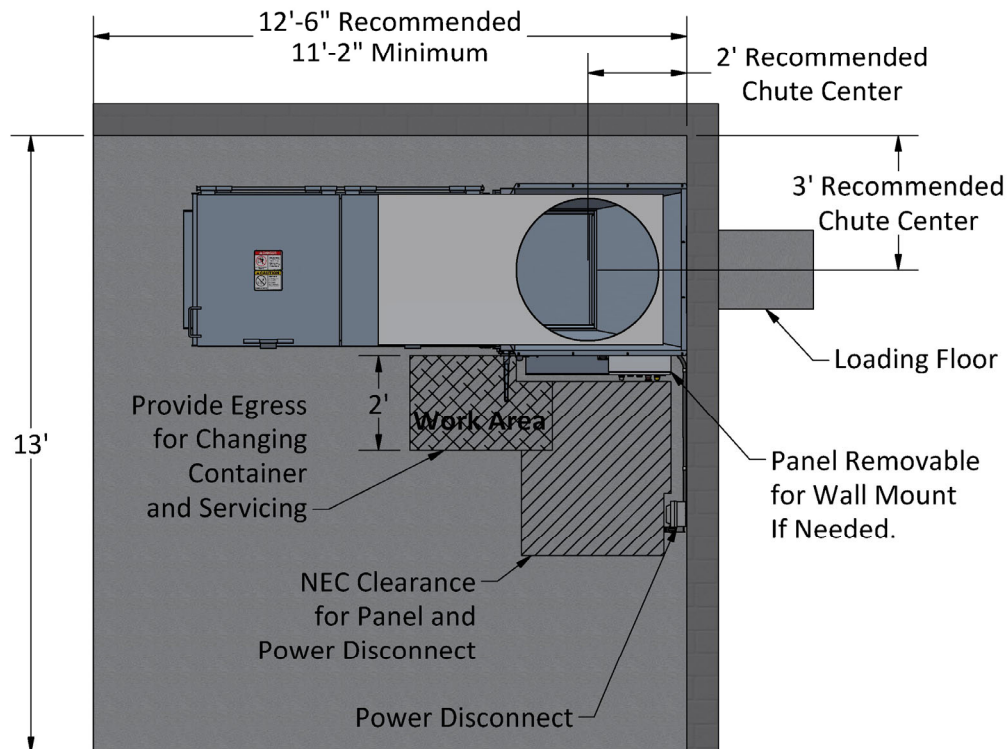
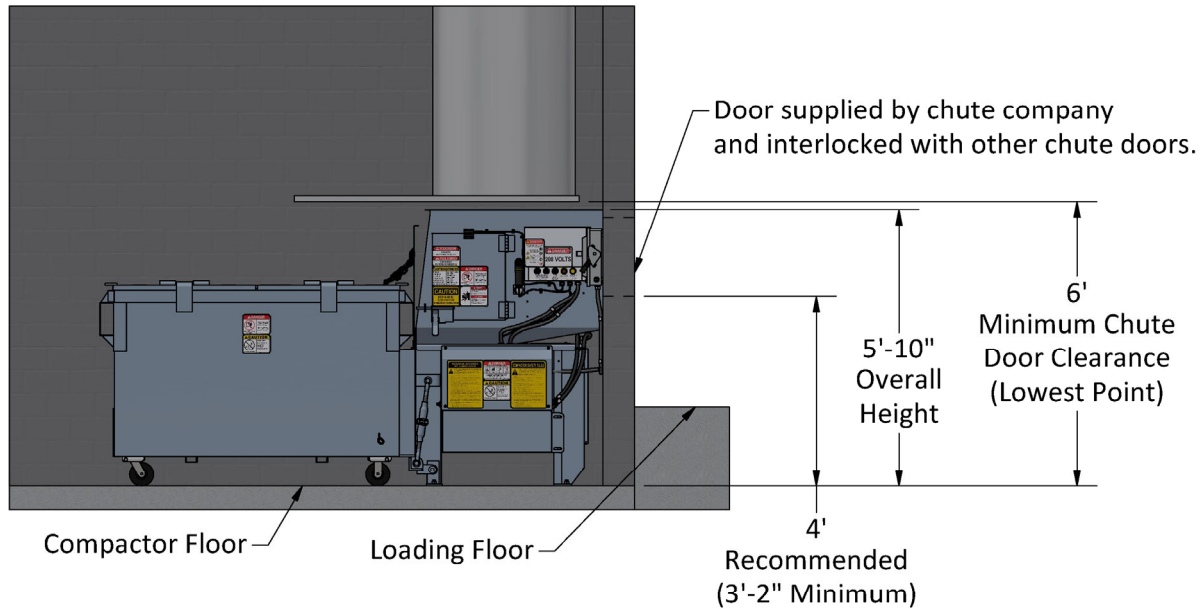

PSI Waste Equipment Services, Inc.
31130 Industry Drive BLDG A
Tavares, FL 32778
352-742-4774

www.psiwaste.com equipment@psiwaste.com

Spacing Requirements (continued)

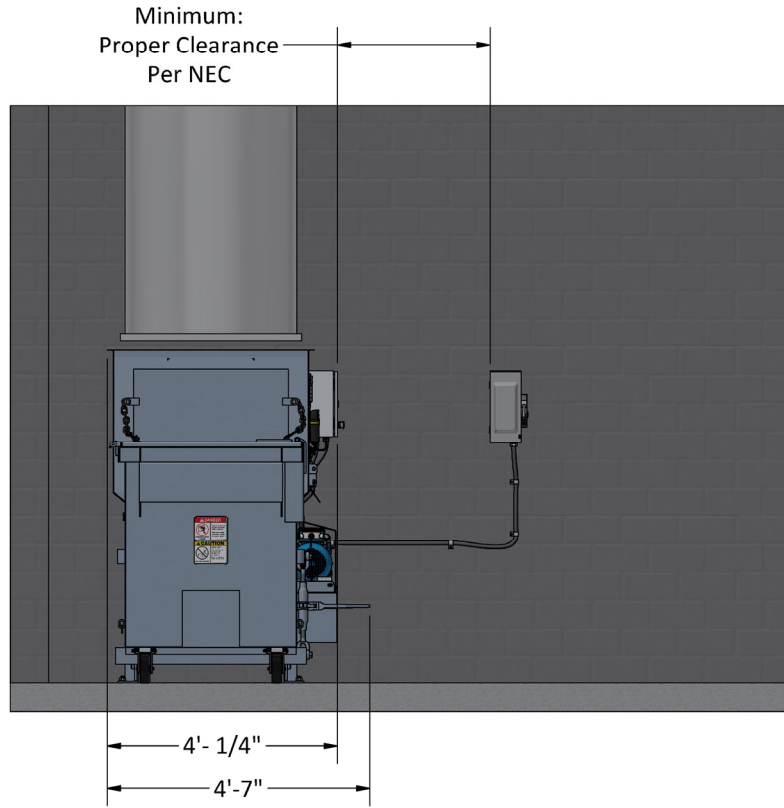

Slab Requirements

